

# ERITROSINA

CAROLINA DIEGO



### ERITROSINA

El E127 o eritrosina es un compuesto organoyodado, concretamente un derivado de la fluorona. Es un pigmento rosa que se utiliza principalmente como colorante alimentario, tinta de imprenta o mancha biológica.

Se trata de un xenoestrógeno, un compuesto nuevo, diseñado y desarrollado por el ser humano. Actualmente, la eritrosina está prohibida como aditivo alimentario y se está estudiando su posible impacto ecológico y en la salud humana.

### ERYTHROSINE

E127 or erythrosine is an organo-iodine compound, specifically a fluorone derivative. It is a pink dye that is mainly used as a food colouring, printing ink or biological dye. It is a xenoestrogen, a new compound, designed and developed by humans.

Erythrosine is currently banned as a food additive and its potential ecological and human health impact is under study.

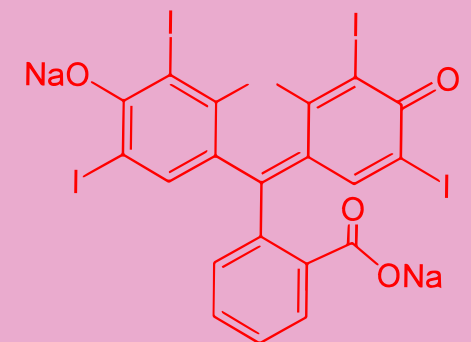









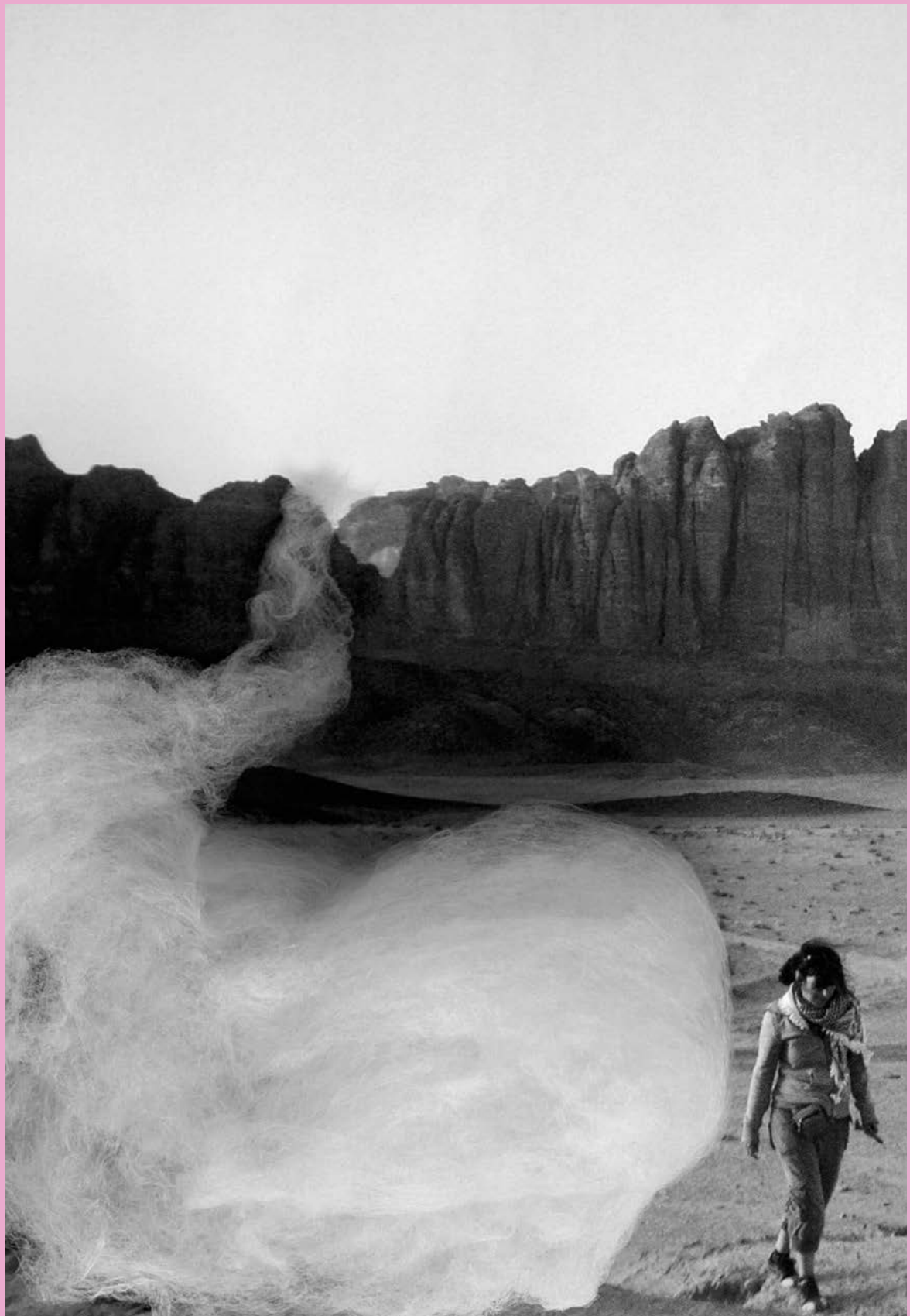

























































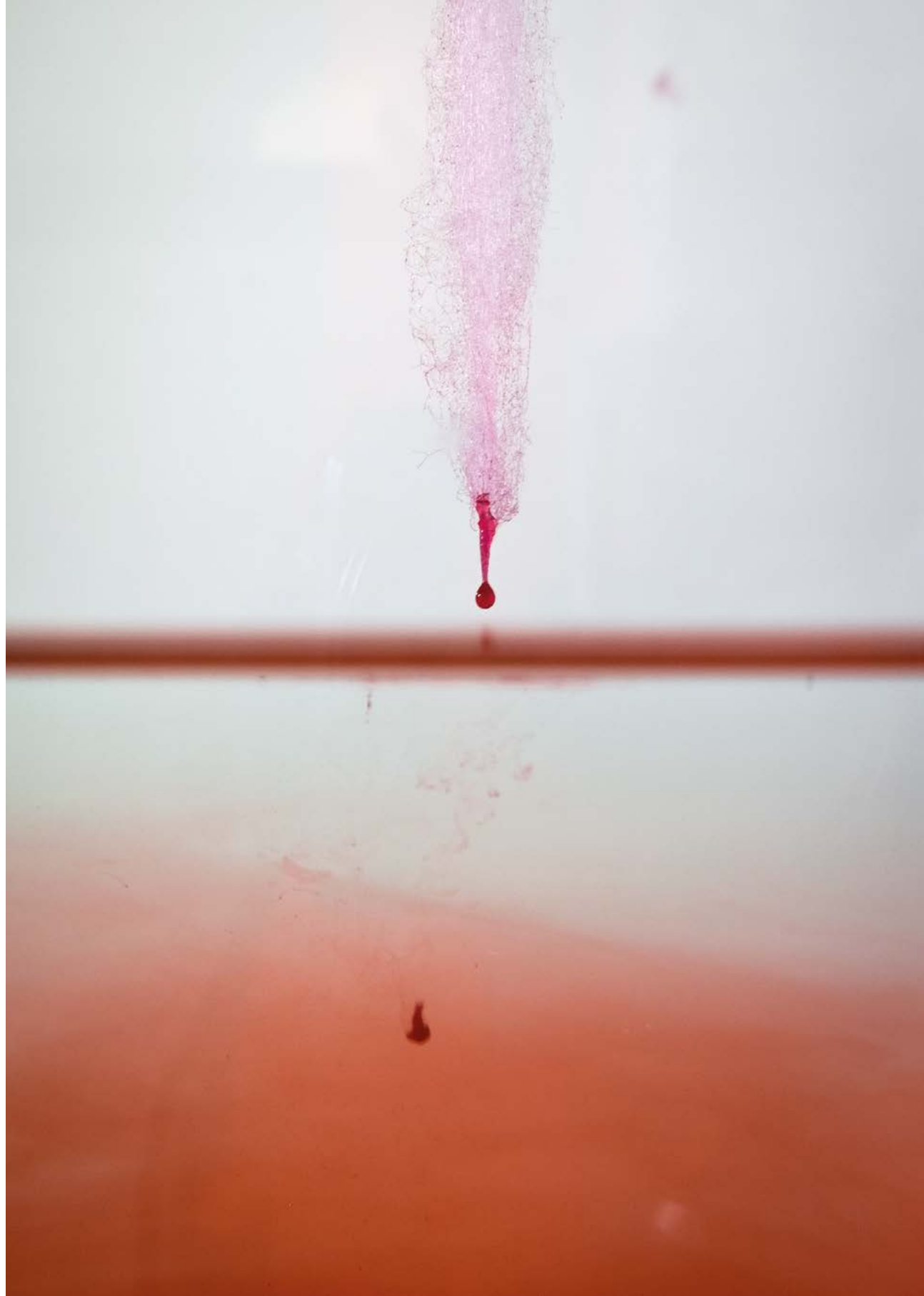











2015\_Alicante.JPG



2013\_Santander.JPG



2012\_Ámsterdam.JPG



2007\_Wadi Rum\_Jordania.JPG



2007\_Petra\_Jordania.JPG



1993\_Londres.JPG



1993\_Londres.JPG



1991\_Alicante.JPG



1991\_Valencia.JPG



1991\_Santillana\_del\_Mar.JPG



1991\_Madrid.JPG



1992\_Cornillas\_Cantabria.JPG



1989\_Castellón.JPG



1988\_Valladolid.JPG



1987\_Cáceres.JPG



1987\_Madrid.JPG

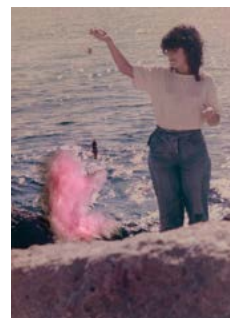

1986\_Alicante.JPG



1981\_Palencia.JPG



1980\_Pamplona.JPG



1976\_Yo\_Zaragoza.JPG



1976\_Alicante.JPG



1973\_Cádiz.JPG



1971\_Valencia.JPG



1961\_Alicante.JPG



1959\_Mamá.JPG



1919\_Abuella\_Valladolid.JPG

May 29, 1962

J. BOWE

3,036,532

COTTON CANDY MACHINE WITH PRODUCT OF ALTERNATING COLORS

Filed June 28, 1960

2 Sheets-Sheet 1

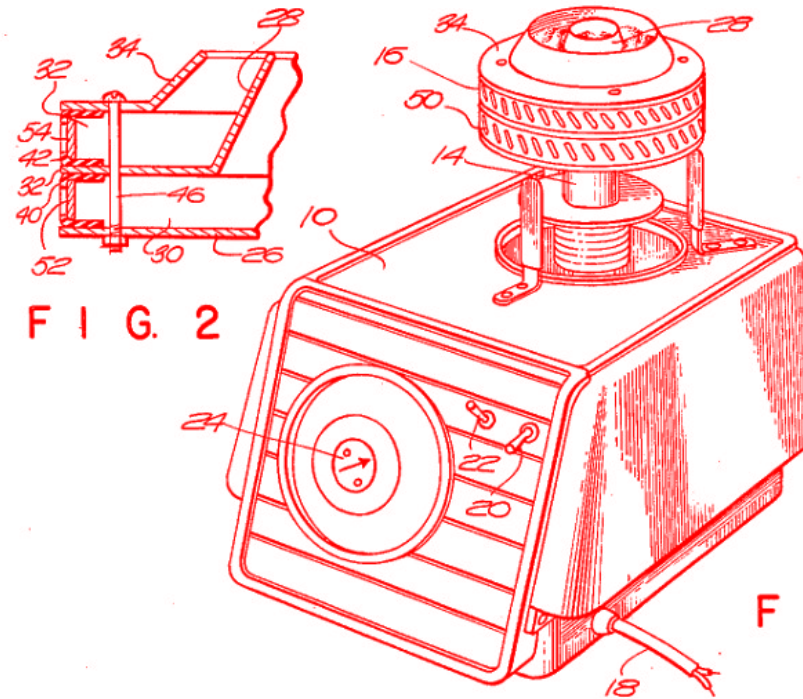

FIG. 2

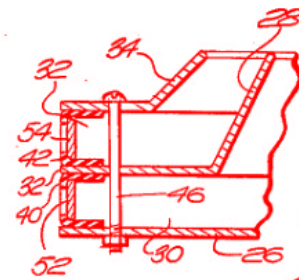

FIG. 1

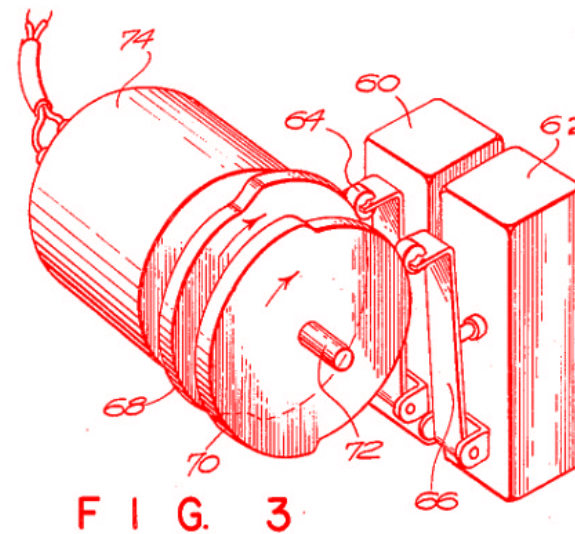

FIG. 3

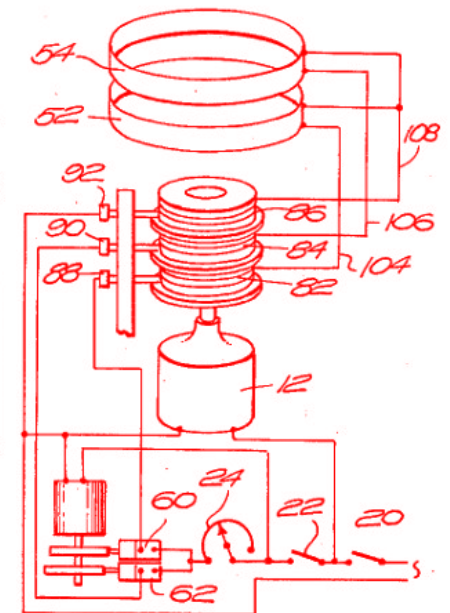

FIG. 4

INVENTOR.  
 JOHN BOWE  
 BY *Morse Altman*

ATTORNEYS

© 2024 Editorial UCA  
© de las fotografías: Carolina Diego  
© del texto: Jorge Pulla

Editorial UCA  
Servicio de Publicaciones  
de la Universidad de Cádiz  
Calle Doctor Marañón, 3  
11002 Cádiz  
<https://publicaciones.uca.es>

DL CA 324-2024  
ISBN 978-84-9828-945-9

Edición  
Carolina Diego y Mati Martí

Diseño  
Mati Martí

Traducción  
Jose Miguel Martínez

Preimpresión  
Estudio Paco Mora

Imprenta  
La Imprenta CG

#### Cuaderno de la Kursala nº 104

Este libro fue publicado con motivo de la exposición "Eritrosina", que tuvo lugar en la Sala Kursala de la Universidad de Cádiz del 17 de enero al 28 de febrero de 2025.

Sala Kursala  
Edificio Constitución 1812  
Paseo Carlos III, 3  
11003 Cádiz

Programación y comisariado  
Jesús Micó

Organizan y patrocinan  
Servicio de Extensión Universitaria.  
Vicerrectorado de Sostenibilidad  
y Cultura.  
Editorial UCA. Vicerrectorado de  
Investigación y Transferencia.  
Universidad de Cádiz.

# ERITROSINA

La familia constituye un ámbito ambiguo; en su seno, las mejores intenciones pueden acarrear las más funestas consecuencias; es el ámbito en el que crecemos y que nos sirve de sustrato y, a la vez, el límite opresivo contra el que nos formamos.

CAROLINA DIEGO aborda en este proyecto la naturaleza de la institución familiar desde la particularidad de su trayectoria vital. Proveniente de tres generaciones de algodoneros de azúcar, se enfrenta al "monstruo dulce" (metáfora perfecta de la familia y la herencia) que la ha marcado desde la infancia.

Este trabajo surge de la doble relación que con la vida errabunda y móvil del feriante establece la autora: por un lado, el ámbito familiar y de la pequeña comunidad, acogedor y protector, espacio de libertad, en el que el futuro aparece marcado por la facilidad y seguridad de la herencia del negocio familiar. Por otro lado, la pesada carga del desarraigo geográfico y la tradición, el castrante peligro de la pereza y la acomodación a las expectativas, el limitador sentimiento de lealtad, gratitud y deuda hacia la familia.

CAROLINA DIEGO, desde las estrategias creativas surrealistas de la apropiación, la intervención y la performance, se sumerge en su álbum familiar para explorar los sentimientos en torno a la familia y la herencia no deseada, sentimientos, que, más allá de su singular experiencia personal, son universales.

**JORGE PULLA**



# ERYTHROSINE

Family is an ambiguous sphere. At its core, the best intentions can have the most dire consequences. It is the sphere we all grow in and that nourishes us, and at the same time the suffocating boundary against which we realize our upbringing. In this personal life project, CAROLINA DIEGO approaches the nature of the family institution from the specificity of her life course.

Coming from a third generation of cotton candy vendors, she faces the “sweet monster”, a perfect metaphor for both family and heritage, that has left a mark on her since childhood. This body of work stems from the author’s twofold relationship with fairground stall vendor’s itinerant, wandering lifestyle: on one side, family and the sense of a small community, a notion both cozy and protective, and a space of freedom in which future is marked by the safety and convenience of an inherited family business. On the flip side, the heavy burden of both tradition and geographical uprooting, the castrating risk of idleness and conforming oneself to everyone’s expectancies, and the limiting feeling of loyalty, gratitude and debt towards the family.

CAROLINA DIEGO dives into her family album utilizing the creative strategies of surrealism, namely, appropriation, intervention and performance, in order to explore her feelings towards the idea of family and unsolicited inheritance. Feelings that, beyond her unique personal experience, are universal.

**JORGE PULLA**

© 2024 Editorial UCA  
© of the images: Carolina Diego  
© of the text: Jorge Pulla

Editorial UCA  
Servicio de Publicaciones  
de la Universidad de Cádiz  
Calle Doctor Marañón, 3  
11002 Cádiz  
<https://publicaciones.uca.es>

DL CA 324-2024  
ISBN 978-84-9828-945-9

Editing  
Carolina Diego y Mati Martí

Book design  
Mati Martí

Translation  
Jose Miguel Martínez

Prepress  
Estudio Paco Mora

Printing  
La Imprenta CG

## Cuaderno de la Kursala nº 104

This book was published on the occasion of the exhibition 'Eritrosina', which took place in the Sala Kursala of the University of Cadiz from January 17 to February 28 2025.

Sala Kursala  
Edificio Constitución 1812  
Paseo Carlos III, 3  
11003 Cádiz

Programming and curatorship  
Jesús Micó

Organizers and sponsors  
Servicio de Extensión Universitaria.  
Vicerrectorado de Sostenibilidad  
y Cultura.  
Editorial UCA. Vicerrectorado de  
Investigación y Transferencia.  
Universidad de Cádiz.

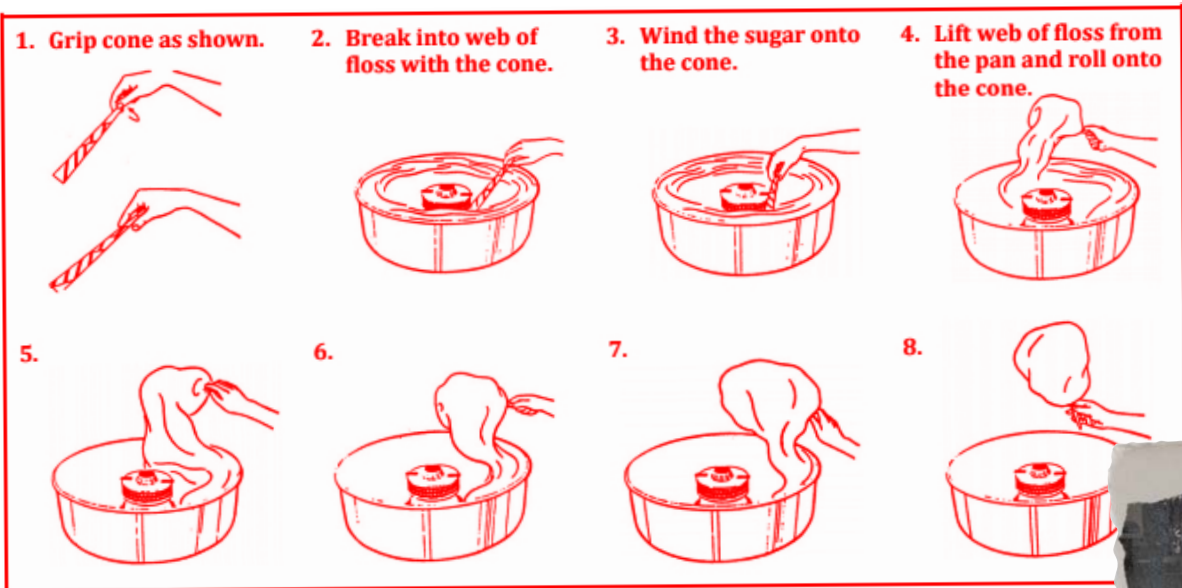

*A Carlos y Pilar, mis padres, por el amor y los cuidados.  
Al monstruo, por lo que me ha enseñado.*

*To Carlos and Pilar, my parents, for their love and care.  
To the monster, for what he has taught me.*

CANDY MACHINE.

(Application filed Dec. 23, 1897.)

(No Model.)

Fig. 1.

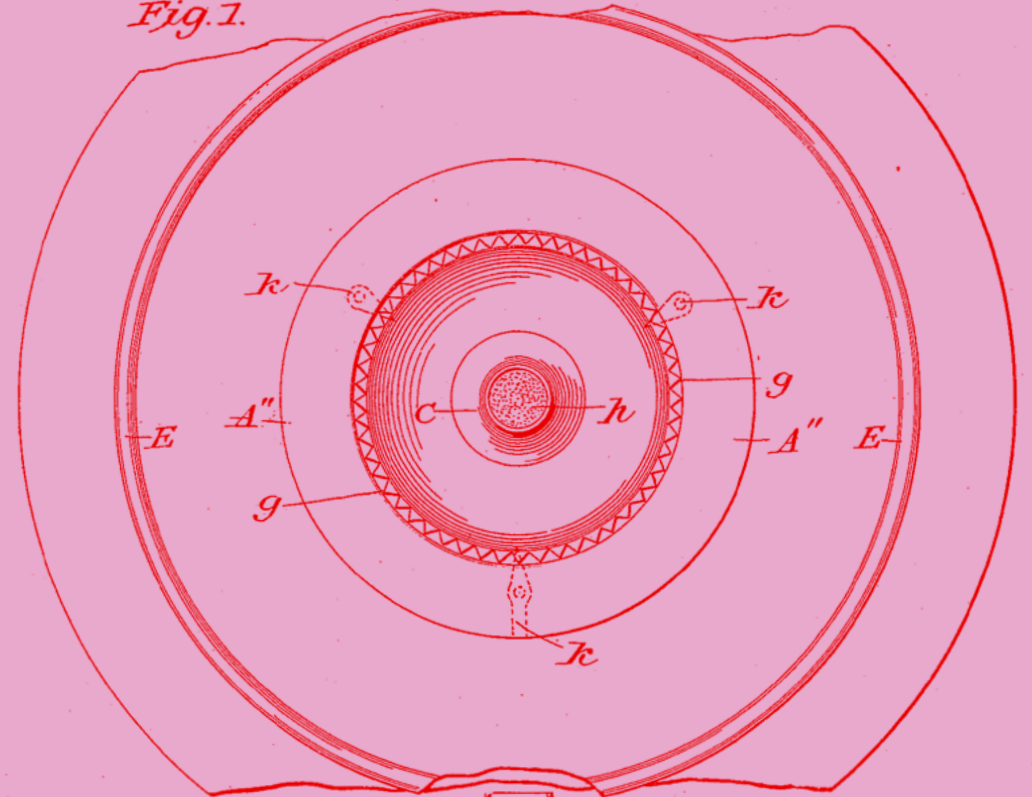
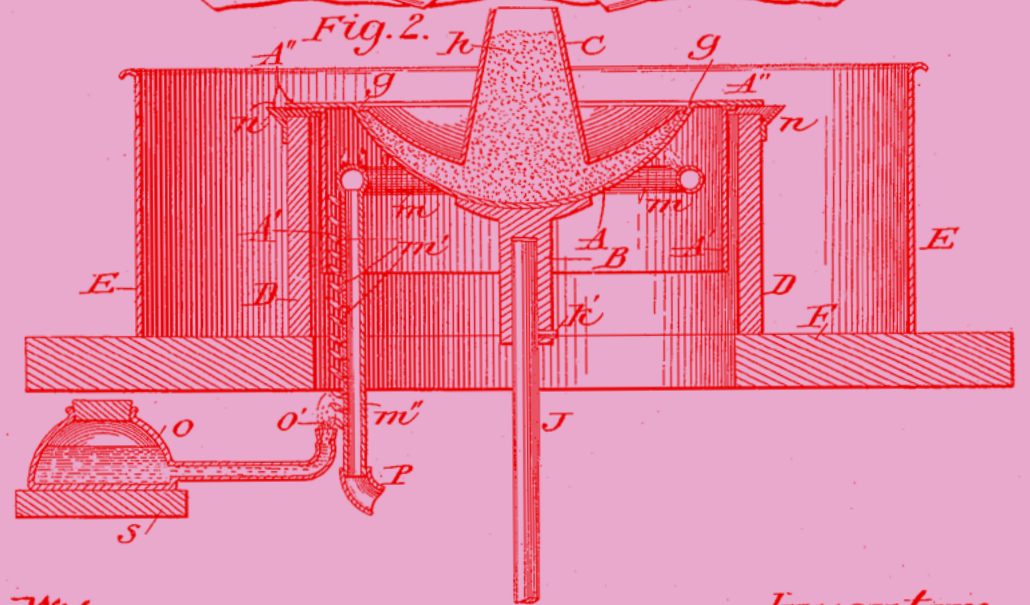
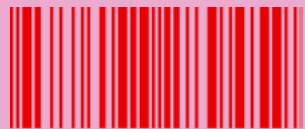

Fig. 2.



Witnesses.  
*J. C. Fisher*  
*M. D. Kinney*

Inventors.  
*William J. Morrison*  
*John C. Wharton.*



9788498289459